



QRD 60/80 PLUS

The QRD 60/80 PLUS barrier is designed for vehicle control in restricted access areas with heavy traffic.very heavy traffic. External cabinet in steel with cataphoresis treatment painted in polyester. 230 Vac geared motor in oil bath and encoder. Programmable control panel with deceleration functions at the end of the travel and obstacle detection system. Incorporates manual release for emergency maneuver. Optionally it can be installed oval arm with led lighting, up to 8 m.

Technical Specifications	QRD 60 PLUS	QRD 80 PLUS
Power	230 Vac; 50 60Hz	230 Vac; 50 60Hz
Engine	230 Vac (self-ventilated)	230 Vac (self-ventilated)
Torque	650 Nm	1.000 Nm
Power	290 W	290 W
Reducer	In oil bath	In oil bath
End-of-stroke deceleration	Adjustable microswitches	Adjustable microswitches
Arm length		
Oval arm H118c	6 m	8 m
Round arm D80	6 m	-
Maneuvering time	9 s	9 s
Investment per impact	Yes	Yes
Thermal range	-30°C /+60°C	-30°C /+60°C
Thermal range	2.000 c/d	2.000 c/d
Protection	IP 54	IP 54
Weight	97 Kg	97 Kg

Dimensions and Details

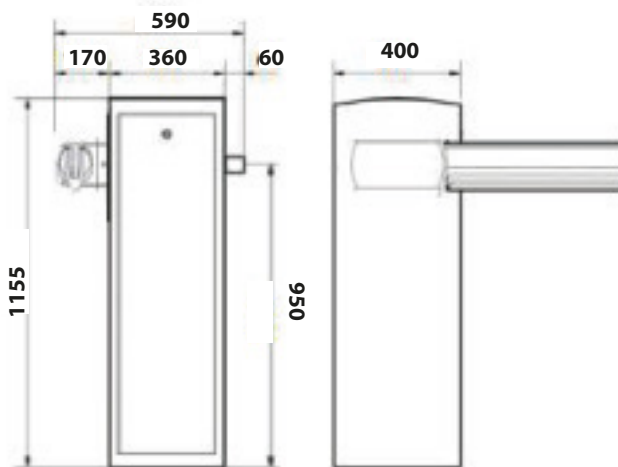

- 230 Vac electromechanical barrier with encoder.
- Use in heavy traffic, up to 2,000 cycles/day.
- Torque control with reversal in case of obstacle.
- Quick external release.
- Easy left/right hand changeover.
- Valid for very heavy traffic.
- **Manufacture in stainless steel on request.**

Related Accesories



Fork



Pendulum foot



Skirt



Valance



Oval Arm H118



Round Arm D80